



WARNING! 1.877.FASTOYS

TRINITY RACING DOES NOT TAKE RESPONSIBILITY FOR DAMAGES THAT MAY OCCUR DURING OPERATION OF YOUR VEHICLE UNDER IMPROPER JET SETTINGS. IT IS THE FINAL RESPONSIBILITY OF THE OWNER/RIDER TO ADJUST JETTING TO SPECIFIC RIDING CONDITIONS AND ELEVATION BEFORE RIDING.

PLEASE FOLLOW ALL OF THESE INSTRUCTIONS CAREFULLY.
KAWASAKI TERYX POWERFLOW INSTRUCTIONS

INSTALLATION PROCEDURE

1. Remove the airbox and clean thoroughly.
2. Cut off the factory plastic ring on airbox. **DO NOT** cut a bigger than **3" 5/8** diameter (See figure #1)
3. After cutting hole in airbox place billet adapter inside the airbox and insert hole then mark the mounting holes for the billet adapter.
4. Drill the marked locations with a 7/32 drill bit.
2. Install the billet adapter from the inside of the airbox with the Trinity Racing logo at the top of the airbox. Insert the bolts and washers from the carburetor side of the airbox and then secure it with blue loctite then tighten bolts.
3. Install Outerwear over new filter.
5. Install the filter onto the billet adapter and make sure the rubber neck of the air filter is completely free of oil. Tighten the filter clamp securely, but do not over tighten and cut into the rubber neck of the filter.
6. Reinstall the air box assemble with lid (if you choose to reinstall the airbox lid) onto the vehicle. Be sure to tighten and double-check all the nuts and bolts you have installed.
7. Check your vehicles jetting. Depending on your modifications and riding altitude, a jetting change may be required for your ATV to run properly.

To take full advantage of your new Stage IV Powerflow™ Kit, Trinity Racing recommends purchasing our Stage IV Exhaust system and Stage IV EFI fuel controller to optimize your intake and electronic fuel injection systems.

Without a Stage IV EFI fuel controller, your ATV will run a lean fuel mixture which can cause engine malfunction.

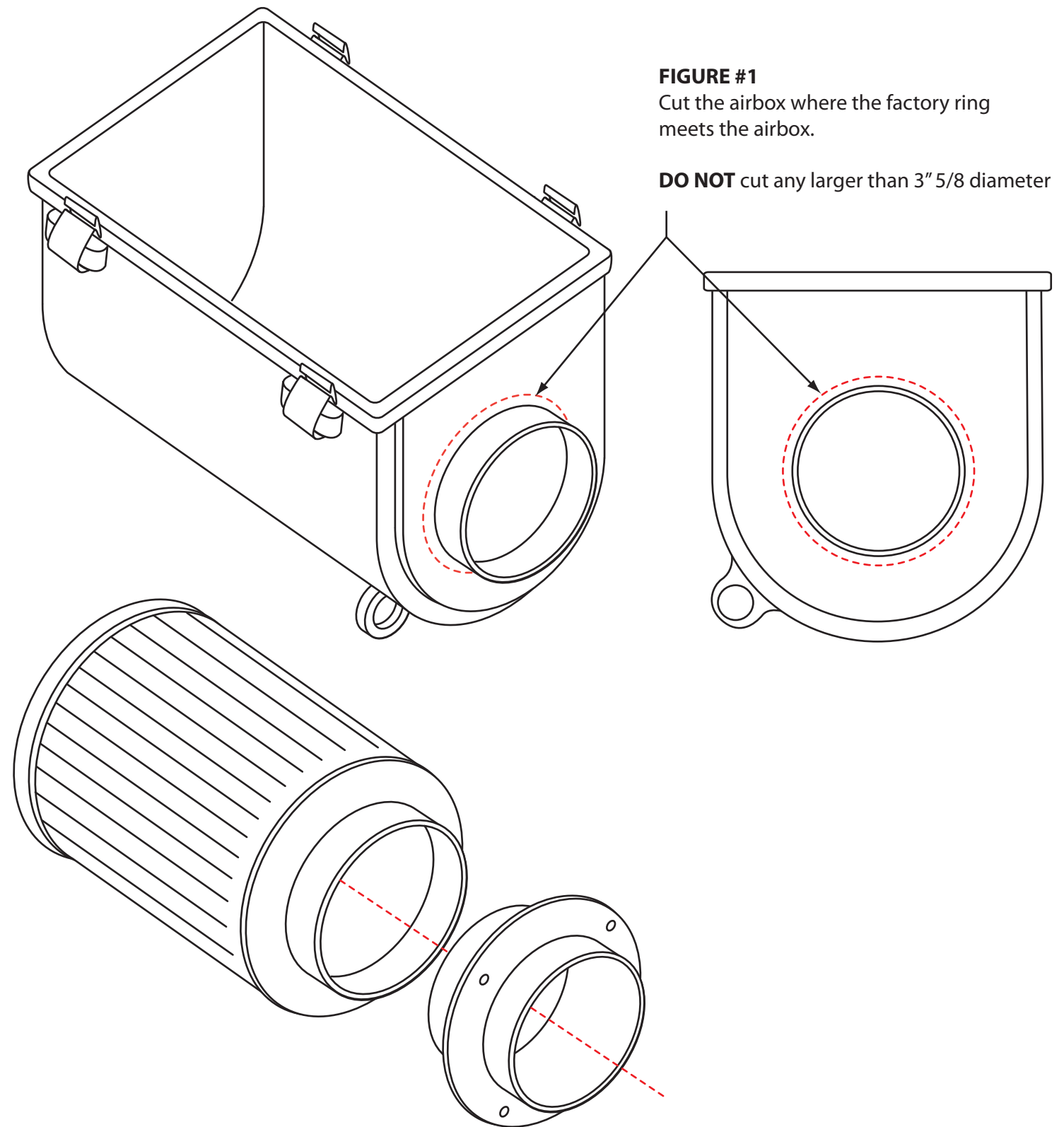

FIGURE #1
Cut the airbox where the factory ring meets the airbox.

DO NOT cut any larger than 3" 5/8 diameter

THANK YOU FOR YOUR BUSINESS. HAVE A FUN AND SAFE RIDE!