



**WARNING!**

**1.877.FASTOYS**

TRINITY RACING DOES NOT TAKE RESPONSIBILITY FOR DAMAGES THAT MAY OCCUR DURING OPERATION OF YOUR VEHICLE UNDER IMPROPER JET SETTINGS. IT IS THE FINAL RESPONSIBILITY OF THE OWNER/RIDER TO ADJUST JETTING TO SPECIFIC RIDING CONDITIONS AND ELEVATION BEFORE RIDING

Due to the different riding conditions and limitations of the powdercoating process, Trinity Racing cannot guaranty the **optional** powdercoated colors life expectancy on our exhaust systems.

**NOTE:**

To ease installation we recommend using WD40 or similar product to lubricate joint(s) on the Head & Mid pipes before installation.

**PLEASE FOLLOW ALL OF THE INSTRUCTIONS CAREFULLY**  
**TERYX EXHAUST INSTRUCTIONS**

**INSTALLATION INSTRUCTIONS:**

Save your stock parts. Some items may be needed for installation of the new system.

- 1) It is not mandatory, but removing the bed makes installation MUCH easier.
- 2) Remove the stock exhaust system. Make sure you keep the exhaust gaskets and hardware to hold the new head pipes onto the engine.
- 3) Place the new head pipes onto the engine making sure the exhaust gaskets are installed and use the stock hardware to loosely hold pipes in place. See figure 1 for orientation.
- 4) Connect the mid sections to the head pipes. See figure 1 for orientation.
- 5) Install the last ceramic coated exhaust pipe to the mid section on the driver's side. See figure 1 for orientation.
- 6) Using the 8X20mm bolts install the muffler flanges onto the mufflers.
- 7) Bolt the L bracket to the muffler bracket using 8x20mm bolts. See figure 2.
- 8) Carefully slide the muffler bracket over the mufflers and loosely clamp them down using the 8x30mm bolt.
- 9) Install the mufflers to the exhaust system using the 8x40mm bolt, washer, and nut to hold them securely to the frame.
- 10) Install the springs to hold all slip fittings together.
- 11) Now tighten all the fasteners that hold the exhaust system on the UTV. Be sure to check all clearances i.e. hoses, plastics, cables, etc.
- 12) Install the muffler end caps using the 5x10mm bolts and washers.
- 13) On carbureted models rejet carbs with main supplied jet kit. The #45 pilot goes in the front carb and the #50 goes in the rear. One washer is to be placed under each needle. This of course is a baseline jetting setup for a completely stock unit with our exhaust system. Final jetting is the customer responsibility.
- 14) After your first ride please recheck all hardware for tightness.

**(EFI MODELS ONLY)**

**To take full advantage of your new Stage IV Exhaust System, Trinity Racing highly recommends purchasing our Stage IV Powerflow intake System and Stage IV EFI fuel controller to optimize your intake and electronic fuel injection systems.**

**Without a Stage IV EFI fuel controller, your ATV will run a lean fuel mixture which can cause engine damage or failure.**

---

**THANK YOU FOR YOUR BUSINESS. HAVE A FUN AND SAFE RIDE!**

TRINITY RACING • 9242 HYSSOP, RANCHO CUCAMONGA, CA 91730

WWW.TRINITYRACING.COM • 909.373.1337 • INFO@TRINITYRACING.COM



**WARNING!**

**1.877.FASTOYS**

TRINITY RACING DOES NOT TAKE RESPONSIBILITY FOR DAMAGES THAT MAY OCCUR DURING OPERATION OF YOUR VEHICLE UNDER IMPROPER JET SETTINGS. IT IS THE FINAL RESPONSIBILITY OF THE OWNER/RIDER TO ADJUST JETTING TO SPECIFIC RIDING CONDITIONS AND ELEVATION BEFORE RIDING

**PARTS LIST:**

- (1) 8x40mm Bolts
- (1) 8x30mm Bolts
- (10) 8x20mm Bolts
- (1) Nylock Nut
- (1) Flat Washer
- (2) Tabs
- (4) Springs
- (12) 5x10mm Bolts
- (12) Lock Washers
- (1) Jet Kit for **Carb Models Only**

**FIGURE 1**

FRONT

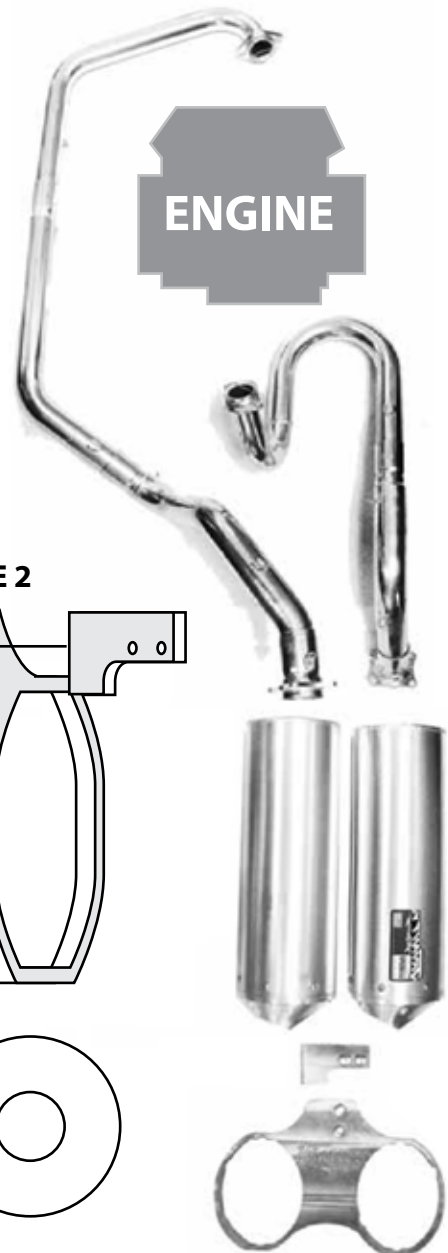

**ENGINE**

**FIGURE 2**

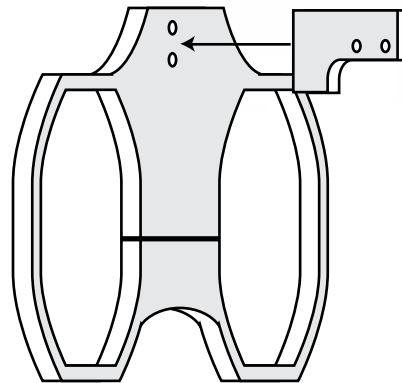

REAR

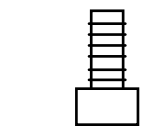
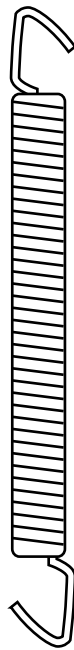
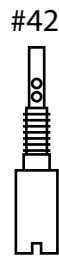
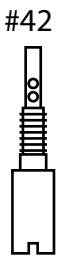
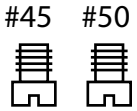
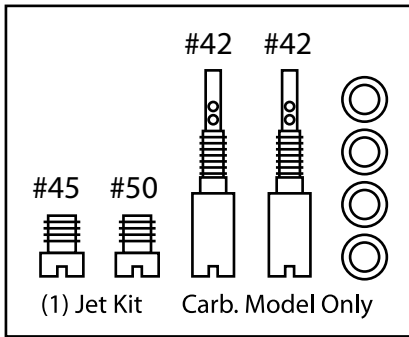

(12) 5x10mm Bolts

(12) Lock Washers

(4) Springs

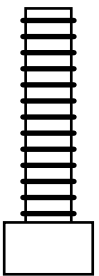

(1) 8x40mm Bolts

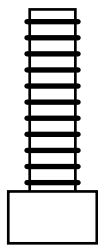

(1) 8x30mm Bolts

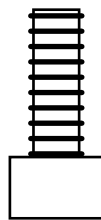

(10) 8x20mm Bolts

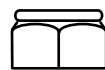

(1) Nylock Nut

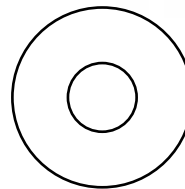

(1) Flat Washer

**THANK YOU FOR YOUR BUSINESS. HAVE A FUN AND SAFE RIDE!**

TRINITY RACING • 9242 HYSSOP, RANCHO CUCAMONGA, CA 91730

WWW.TRINITYRACING.COM • 909.373.1337 • INFO@TRINITYRACING.COM